

Name \_\_\_\_\_ Date \_\_\_\_\_ Partners \_\_\_\_\_

## LAB 6: WORK AND ENERGY



*Energy is the only life and is from the Body; and Reason is the bound or outward circumference of energy. Energy is eternal delight.*

–William Blake

### OBJECTIVES

- To extend the intuitive notion of work as physical effort to a formal mathematical definition of work,  $W$ , as a function of both the force on an object and its displacement.
- To develop an understanding of how the work done on an object by a force can be measured.
- To understand the concept of power as the rate at which work is done.
- To understand the concept of kinetic energy and its relationship to the net work done on an object as embodied in the *work–energy principle*.
- To understand the concept of potential energy.
- To understand the concept of mechanical energy of a system.
- To investigate situations where mechanical energy is conserved and those where it is not.

### OVERVIEW

Two new concepts are useful in further studying various types of physical interactions—*work* and *energy*. In this lab, you will begin the process of understanding the scientific definitions of *work* and *energy*, which in some cases are different from the way these words are used in everyday language. We will introduce the principle of *Conservation of Energy*.

You will begin by comparing your intuitive, everyday understanding of work with its formal mathematical definition. You will first consider the work done on a small point-like object by a constant force. There are, however, many cases where the

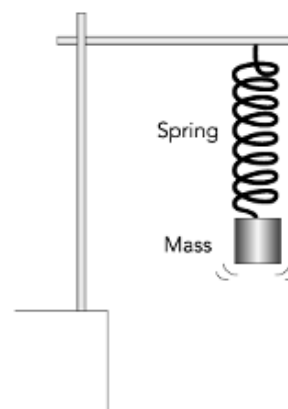

force is not constant. For example, the force exerted by a spring increases the more you stretch the spring. In this lab you will learn how to measure and calculate the work done by any force that acts on a moving object (even a force that changes with time).

Often it is useful to know both the total amount of work that is done, and also the rate at which it is done. The rate at which work is done is known as *power*. Energy (and the concept of conservation of energy) is a powerful and useful concept in all the sciences. It is one of the more challenging concepts to understand. You will begin the study of energy in this lab by considering *kinetic energy*—a type of energy that depends on the velocity of an object and to its mass.

By comparing the change of an object's kinetic energy to the net work done on it, it is possible to understand the relationship between these two quantities in idealized situations. This relationship is known as the *work-energy principle*. You will study a cart being pulled by the force applied by a spring. How much net work is done on the cart? What is the kinetic energy change of the cart? How is the change in kinetic energy related to the net work done on the cart by the spring?

Suppose you lift an object steadily at a slow constant velocity near the surface of the Earth so that you can ignore any change in kinetic energy. You must do work (apply a force over a distance) to lift the object because you are pulling it away from the Earth. The lifted object now has the *potential* to fall back to its original height, gaining kinetic energy as it falls. Thus, if you let the object go, it will gain kinetic energy as it falls toward the Earth.

It is very useful to define the *gravitational potential energy* of an object at height  $y$  (relative to a height  $y_0 \equiv 0$ ) as *the amount of work needed to move the object away from the Earth at constant velocity through a distance  $y$* . If we use this definition, the potential energy of an object is a maximum when it is at its highest point. If we let it fall, the potential energy becomes smaller and smaller as it falls toward the Earth while the kinetic energy increases as it falls. We can now think of kinetic and potential energy to be two different forms of mechanical energy. We define the **mechanical energy** as the sum of these two energies.

Is the mechanical energy constant during the time the mass falls toward the Earth? If it is, then the amount of mechanical energy doesn't change, and we say that mechanical energy is *conserved*. If mechanical energy is conserved in other situations, we might be able to hypothesize a law of conservation of mechanical energy as follows: *In certain situations, the sum of the kinetic and potential energy, called the mechanical energy, is a constant at all times; it is conserved.*

The concept of mechanical energy conservation raises a number of questions. Does it hold quantitatively for falling masses? Is the sum of the calculated potential and kinetic energies exactly the same number as the mass falls? Can we apply a similar concept to masses experiencing other forces, such as those exerted by springs? Perhaps we can find another definition for *elastic potential energy* for a mass-spring system. In that case could we say that mechanical energy will also be conserved for an object attached to a spring? Often there are frictional forces involved with motion. Will mechanical energy be conserved for objects experiencing frictional forces, like those encountered in sliding?

You will explore the common definition of *gravitational potential energy* to see if it makes sense. You will then measure the *mechanical energy*, defined as the sum of gravitational potential energy and kinetic energy, to see if it is conserved when the gravitational force is the only force acting. Next, you will explore a system where the only net force is exerted by a spring and see the definition of *elastic potential energy*. You will measure the mechanical energy of this system and see if it is conserved. Finally, you will explore what effects sliding frictional forces or air resistance forces have on systems. You will explore whether or not mechanical energy is still conserved in such systems.

### **INVESTIGATION 1: THE CONCEPTS OF PHYSICAL WORK AND POWER**

While you all have an everyday understanding of the word “work” as being related to expending effort, the actual physical definition is very precise, and there are situations where this precise scientific definition does not agree with the everyday use of the word.

You will begin by looking at how to calculate the work done by constant forces, and then move on to consider forces that change with time.

Let’s begin with a prediction that considers choosing among potential “real-life” jobs.

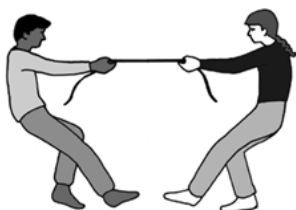

**Prediction 1-1:** Suppose you are president of the Load ‘n’ Go Company. A local college has three jobs (see below) it needs to have done and it will allow your company to choose one before offering the other two jobs to rival companies. All three jobs pay the same total amount of money. (Continued on next page.)

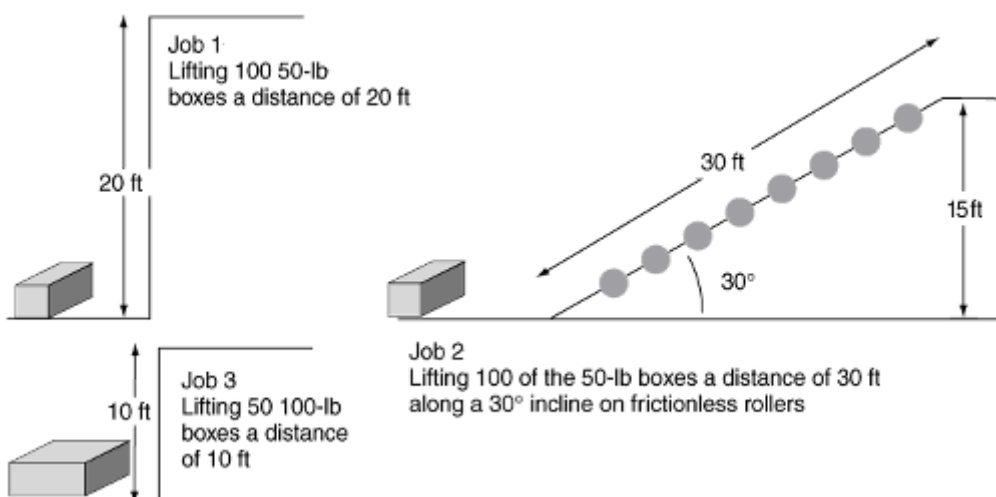

Which one would you choose for your crew? Explain why. **Do this before coming to lab.**

The following activities should help you to see whether your choice makes the most sense. You will need the following:

- 5 N spring scale
- track inclinometer
- motion cart with no friction pad
- clamps and rods
- 2 m motion track that can be inclined
- digital mass scale
- two – ½ kg masses

In physics, work is not simply effort. In fact, the physicist's definition of work is precise and mathematical. To have a full understanding of how work is defined in physics, we need to consider its definition for a very simple situation and then enrich it later to include more realistic situations.

If a rigid object or point mass experiences a constant force along the same line as its motion, the *work* done by that force is defined as the product of the force and the displacement of the center of mass of the object. Thus, in this simple situation where the force and displacement lie along the same line

$$\Delta W = F_x \Delta x \quad (1)$$

where  $\Delta W$  represents the work done by the force,  $F_x$  is the force, and  $\Delta x$  is the displacement of the center of mass of the object along the  $x$  axis. Note that if the force and displacement (direction of motion) are in the same direction (i.e., both positive or both negative), the *work done by the force is positive*. On the other hand, a force acting in the direction opposite to displacement does *negative work*. For example, an opposing force that is acting to slow down a moving object is doing *negative work*.

**Question 1-1:** Does effort necessarily result in physical work? Suppose two people are in an evenly matched tug of war. They are obviously expending effort to pull on the rope, but according to the definition are they doing any *physical work* as defined above? Explain.

---

**ACTIVITY 1-1: WORK WHEN THE FORCE AND DISPLACEMENT LIE ALONG THE SAME LINE AND WHEN THEY DON'T**

In this activity you will measure the force needed to pull a cart up an inclined ramp using a spring scale. You will examine two situations. First, you will exert a force parallel to the surface of the ramp, and then you will exert a force at an angle to the ramp. You will then be able to see how to calculate the work when the force and displacement are not in the same direction in such a way that the result makes physical sense.

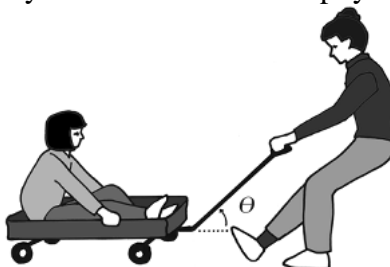

1. Set up the cart and ramp as shown in the diagram below. Add two  $\frac{1}{2}$  kg black rectangular masses to the cart. Weigh mass of cart and the additional masses. Attach the hook on the spring scale to the screw on top of the cart. Support one end of the ramp so that it is inclined to an angle of about  $10^\circ$ .

Mass of cart: \_\_\_\_\_

“mass #1”: \_\_\_\_\_

“mass #2”: \_\_\_\_\_

Total mass of cart & additional masses: \_\_\_\_\_

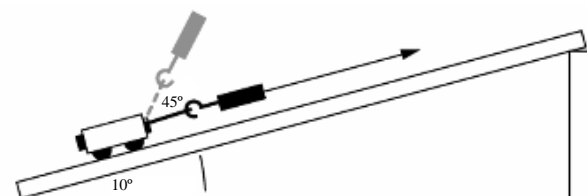

2. Find the force needed to pull the cart up the ramp at a constant velocity. Pull the cart so that the spring scale is always *parallel to the ramp*. Pull the cart along the ramp and write down the average force on the spring scale. Make sure the spring scale is zeroed before making your measurement. Ask you TA for help if needed.

Average force pulling parallel to ramp: \_\_\_\_\_

**Prediction 1-2:** Suppose that the force is not exerted along the line of motion but is in some other direction, like at an angle of  $45^\circ$  to the ramp. If you try to pull the cart up along the same ramp in the same way as before (again with a constant velocity), only this time with a force that is not parallel to the surface of the ramp, will the force probe measure the same force, a larger force, or a smaller force?

3. Now test your prediction by measuring the force needed to pull the cart up along the ramp at a constant velocity, pulling at an angle of about  $45^\circ$  to the surface of the ramp. Measure the  $45^\circ$  angle with a protractor. Measure the force on the spring scale as you pull the cart up *at a slow constant speed* as shown in the diagram above. *Be sure the cart does not lift off the surface of the ramp.*

Average force pulling at  $45^\circ$  to the surface: \_\_\_\_\_

It is the force component parallel to the displacement that is included in the calculation of work. Thus, when the force and displacement are not parallel, the work is calculated by

$$\Delta W = F_x \Delta x = (F \cos \theta) \Delta x = \vec{\mathbf{F}} \cdot \Delta \vec{\mathbf{x}} \quad (2)$$

**Question 1-2:** Discuss how well your observations support this cosine dependence as a reasonable way to calculate the work.

Sometimes more than just the total physical work done is of interest. Often what is more important is the *rate* at which physical work is done. Average power,  $\overline{P}_{av}$ , is defined as the ratio of the amount of work done,  $\Delta W$ , to the time interval,  $\Delta t$ , in which it is done, so that

$$\overline{P}_{av} = \frac{\Delta W}{\Delta t}$$

If work is measured in joules and time in seconds, then the fundamental unit of power is the joule/second, and one joule/second is defined as one watt.

A more traditional unit of power is the horsepower, which originally represented the rate at which a typical work horse could do physical work. It turns out that

$$1 \text{ horsepower (or hp)} = 746 \text{ watts}$$

Those of you who are car buffs know that horsepower is used to rate engines. The engine in a high-performance car can produce hundreds of horsepower.

### **INVESTIGATION 2: WORK DONE BY CONSTANT AND NON-CONSTANT FORCES**

Few forces in nature are constant. A good example of a non-constant force is the force exerted by a spring as you stretch it. In this investigation you will see how to calculate work and power when a non-constant force acts on an object.

You will start by looking at a somewhat different way of calculating the work done by a constant force by using the area under a graph of force vs. position. It turns out that, unlike the equations we have written down so far, which are only valid for constant forces, the method of finding the area under the graph will work for both constant and changing forces.

The additional equipment you will need includes the following:

- motion detector
- rod support for force probe
- motion cart with no friction pad
- masking tape
- spring
- 200 g mass
- index card, 4" x 6"

#### **ACTIVITY 2-1: WORK DONE BY A CONSTANT LIFTING FORCE**

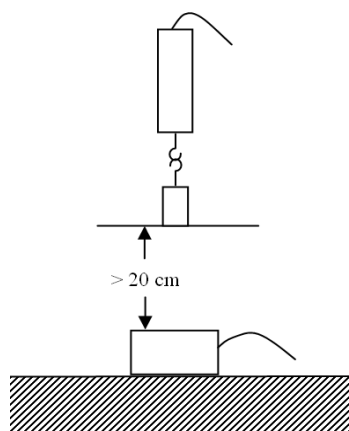

In this activity you will measure the work done when you lift an object from the floor through a measured distance. You will use the force probe to measure the force and the motion detector to measure distance.

1. The motion detector should be on the floor, pointing upward. Use the broad beam setting on the motion detector.
2. Open the experiment file called **L06.A2-1 Work in Lifting**. This will allow you to display velocity and force for 5 s. We will no longer remind you to **check the experimental "Setup"**, but you should always do it.
3. Use masking tape to tape an index card on the bottom of a 200 g hanging mass. This will enable the motion detector to more easily see the position of the mass.
4. **Zero** the force probe with the hook pointing vertically downward. Then hang the 200 g mass from its end. The index card **must** be relatively level or you will receive spurious results. Reattach the card if it is not level. **Begin graphing** and then lift the force probe by hand with the mass attached at a slow, constant speed through a distance of about 1.0 m starting at least 20 cm above the motion detector.

5. Keep trying until you have a set of graphs in which the mass was moving at a reasonably constant speed and had no spurious distance measurements.
6. **Print** one set of graphs for your group report.

**Question 2-1:** Did the force needed to move the mass depend on how high it was off the floor, or was it reasonably constant?

7. You should find a force vs. position graph minimized. Click on **Force vs P** graph and bring it up on the screen.
8. **Print** out one graph for your group report.
9. Use the **statistics features** of the software to find the average force over the distance the mass was lifted. Record this force and distance below. Use the Smart Tool to find the corresponding distance.

Average force: \_\_\_\_\_ Distance lifted: \_\_\_\_\_

10. Calculate the work done in lifting the mass. Show your calculation.

Work done: \_\_\_\_\_

11. Notice that force times distance is also the area of the rectangle under the force vs. position graph. Find the area under the curve by using the **area routine** under appropriate lines. Use the same units as used in 10) above.

Area under force vs. position graph: \_\_\_\_\_

**Question 2-2:** What is the percentage difference between your two determinations of the work? If it is more than 10%, explain.

**Comment:** This activity has dealt with the constant force required to lift an object against the gravitational force at a constant speed. The area under the force vs. position curve always gives the correct value for work, even when the force is not constant.

---

### ACTIVITY 2-2: WORK DONE BY A NON-CONSTANT SPRING FORCE

In this activity you will measure the work done when you stretch a spring through a measured distance. First you will collect data for force applied by a stretched spring vs. distance the spring is stretched, and you will plot a graph of force vs. distance. Then, as in Activity 2-1, you will be able to calculate the work done by finding the area under this graph.

**Comment:** We assume that the force measured by the force probe is the same as the force applied by the cart to the end of the spring. This is a consequence of *Newton's third law*. We have set the force probe to indicate the force of our hand.

1. Set up the ramp, cart, motion detector, force probe, and spring as shown in the diagram. Pay careful attention to your Instructor who will tell you how to mount the springs so they will not be bent. Use the narrow beam on the motion detector.

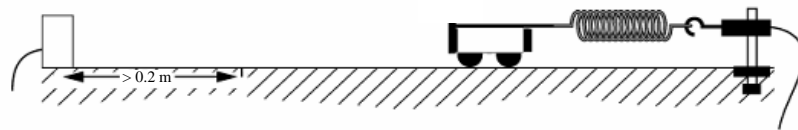

2. Be sure that the motion detector sees the cart over the whole distance of interest—from the position where the spring is just unstretched to the position where it is stretched about 1.0 m.
3. Open the experiment file called **L06.A2-2 Stretching Spring**.
4. **Zero** the force probe with the spring hanging loosely. Then **begin graphing** force vs. position as the cart is moved by hand slowly towards the motion detector until the spring is stretched about 1.0 m. (Keep your hand out of the way of the motion detector.)

5. **Print** out one set of graphs for your group report.

**Question 2-3:** Compare this force–position graph to the one you obtained by lifting the mass in Activity 2-1. Is the spring force a constant force? Describe any changes in the force as the spring is stretched.

**Question 2-4:** Describe how you can use the equation  $\Delta W = F_x \Delta x$  for calculating the work done by a non-constant force like that produced by a spring?

6. Use the **area routine** in the software to find the work done in stretching the spring.

Area under force vs. position graph: \_\_\_\_\_

Investigation 3 will begin with an exploration of the definition of *kinetic energy*. Later, we will return to this method of measuring the area under the force vs. position graph to find the work, and we will compare the work done to changes in the kinetic energy.

<b>INVESTIGATION 3: KINETIC ENERGY AND THE WORK—ENERGY PRINCIPLE</b>
--

What happens when you apply an external force to an object that is free to move and has no frictional forces on it? According to *Newton's second law*, it should experience acceleration and end up moving with a different velocity. Can we relate the change in velocity of the object to the amount of work that is done on it?

Consider a fairly simple situation. Suppose an object is lifted through a distance and then allowed to fall near the surface of the Earth. During the time it is falling, it will experience a constant force as a result of the attraction between the object and the Earth—glibly called gravity or the force of gravity. You discovered how to find the work done by this force in Investigations 1 and 2. It is useful to define a new quantity called *kinetic energy*. You will see that as the object falls, its kinetic energy increases as a result of the

work done by the gravitational force and that, in fact, it increases by an amount exactly equal to the work done.

**Comment:** When an object moves, it possesses a form of energy because of the work that was done to start it moving. This energy is called *kinetic energy*. You should have discovered that the amount of kinetic energy increases with both mass and speed. In fact, the kinetic energy is defined as being proportional to the mass and the square of the speed. The mathematical formula is

$$KE = \frac{1}{2}mv^2 \quad (3)$$

The unit of kinetic energy is the joule (J), the same as the unit of work.

When you apply a net force to an object, the object always accelerates. The force does work and the kinetic energy of the object changes. The relationship between the work done on the object and the change in its kinetic energy is called the *work-energy principle*.

In short, the work-energy principle states that the net work (considering all forces acting on the object) is equal to the change in the object's kinetic energy:

$$\Delta W_{net} = \Delta KE \quad (4)$$

In the next activity, you will examine the work-energy principle by doing work on a cart with a spring and comparing this work to the change in the cart's kinetic energy.

---

### ACTIVITY 3-1: WORK—ENERGY PRINCIPLE

In addition to the material before, you will also need:

- two 0.5 kg black rectangular bar masses to put on cart
1. Set up the ramp, cart, motion detector, force probe, and spring as shown in the diagram that follows. Place the two 0.5 kg bar masses on the cart. If you have difficulty with the motion detector seeing the cart, you can attach an index card to the front of the cart. The friction pad should not be used on the cart.

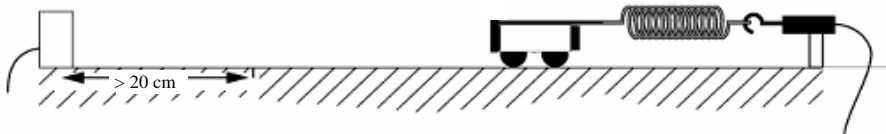

2. Open the experiment file called **L06.A3-1 Work—Energy**.
3. *Be sure that the motion detector sees the cart over the whole distance of interest—from the position where the spring is stretched about 1.0 m to the position where it is just about unstretched.*

4. Measure the mass of the cart and bar masses (separately) **and enter the sum in the formula for kinetic energy**. Click on the calculator screen to do so. The value for the mass in the software now is 1.477 kg. Click on Accept twice (once to accept the value and once to accept the “new” formula) if you change the mass value.

Mass of cart and bar masses: \_\_\_\_\_

5. **Zero** the force probe with the spring hanging loosely. Then pull the cart along the track so that the spring is stretched about 1.0 m from the unstretched position.
6. **Begin graphing**, and release the cart, allowing the spring to pull it back at least to the unstretched position. Make sure you catch the cart before it crashes into the force probe!
7. When you get a good set of graphs, **print** out one set of graphs for your group report.

Note that the top graph displays the force applied by the spring on the cart vs. position. It is possible to find the work done by the spring force for the displacement of the cart between any two positions. This can be done by finding the area under the curve using the **area routine** in the software, as in Activities 2-1 and 2-2. The kinetic energy of the cart can be found directly from the bottom graph for any position of the cart.

8. Find the change in kinetic energy of the cart after it is released from the initial position (where the kinetic energy is zero) to three different final positions. Use the **analysis feature** of the software. Also find the work done by the spring up to that position.

Record these values of work and change in kinetic energy in Table 3-1. You do not need to fill up the table. The first row is for the initial position; determine from your graph the initial position of the cart where it is released and record it in the table.

**Table 3-1**

Position of cart (m)	Kinetic energy (J)	Work done (J)	Percent Difference (difference/average)x100%
<b>Initial position:</b>	0	0	0

**Question 3-1:** Discuss how well your results confirm the work-energy principle.

---

**INVESTIGATION 4: GRAVITATIONAL POTENTIAL ENERGY**

---

Suppose that an object of mass  $m$  is lifted slowly through a distance  $y$ . To cause the object to move upward at a constant velocity, you will need to apply a constant force upward just equal to the gravitational force, which is downward.

We choose to define the gravitational potential energy,  $GPE$  of an object of mass  $m$  to be equal to the work done against the gravitational force to lift it:

$$GPE = mgy \quad (5)$$

A system in which the gravitational force is essentially the only net force is a cart with very small friction moving on an inclined ramp. You can easily investigate the mechanical energy for this system as the cart rolls down the ramp.

In addition to the equipment you have been using, you will need the following:

- motion cart with adjustable friction pad
- track inclinometer
- clamps and rods
- 2-m motion track

---

**ACTIVITY 4-1: GRAVITATIONAL POTENTIAL, KINETIC, AND MECHANICAL ENERGY OF A CART MOVING ON AN INCLINED RAMP**

---

1. Set up the ramp and motion detector as shown below. Use the narrow beam on the motion detector. The ramp should be inclined at an angle of  $10^\circ$  above the horizontal. Use the inclinometer to measure the angle. Ask your TA for help if you need it. The friction pad on the cart should be removed for this activity.

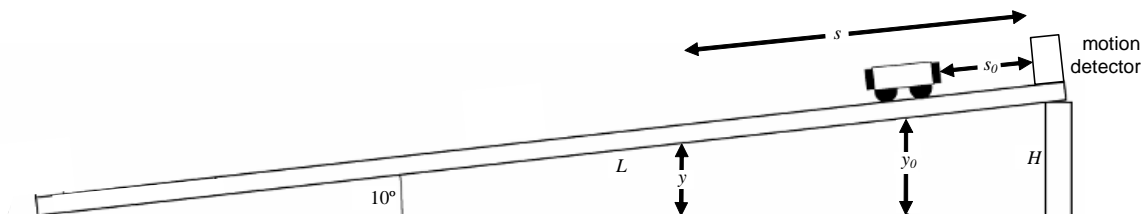

Remember that potential energy is relative, and we can set the zero of potential energy anywhere we want it to be. In this case, we could set it to be zero at the bottom of the ramp or the top of the ramp. Let's simply agree to set it to be zero at the bottom. Then, when we hold the cart at rest at the top of the ramp at a height of

$y_0$  from the table, the gravitational potential energy is  $mgy_0$ . As it rolls down the ramp, this potential energy decreases. Its value at any position  $y$  is given by Eq. (5),  $GPE = mgy$ .

- We can find an equation for  $GPE$  in terms of  $S$ , the position measured by the motion detector *along the ramp*, and  $L$ , the length of the ramp. Look carefully at the above figure. If  $S$  is the distance along the ramp away from the motion detector at time  $t$ , the equation for  $GPE$  is:

$$GPE = mg(L - S)\sin\theta \quad (6)$$

- Measure the mass of the cart.

Mass: \_\_\_\_\_

- Open the experiment file called **L06.A4-1 Inclined Ramp**.
- Enter** the mass of the cart into the formula for kinetic energy. Look near the bottom of the Calculator screen and choose  $m$ . Enter its value where it is indicated and then click on the Accept icon in Experimental Constants. Check the formulas for  $GPE$  and  $KE$  that you find on the calculator screen under Definition to make sure you agree that you are calculating the correct quantities. Finally click on the other Accept icon at the right top.

Notice that mechanical energy is calculated as

$$ME = GPE + KE. \quad (7)$$

**Prediction 4-1:** As the cart rolls down the ramp, how will the kinetic energy change? How will the gravitational potential energy change? How will the mechanical energy change? **Do this before coming to lab.**

- Verify that the motion detector “sees” the cart all the way along the ramp and that the ramp is set at a  $10^\circ$  angle.
- Data Studio* will again utilize auto start and stop in this experiment. The range is 0.4 – 1.7 m relative to the motion detector at the top. Hold the cart at the top of the ramp about 20 cm from the motion detector and START the experiment. Release the cart and catch it at the bottom right before it slams into something. *Data Studio* will automatically stop after car passes 1.7 m. You do not need to click on STOP.
- Print** out one set of graphs for your group report.

**Question 4-1:** Compare your graphs to your prediction above. How are they similar and how are they different?

**Comment:** The mechanical energy, the sum of the kinetic energy and gravitational potential energy, is said to be *conserved* for an object moving only under the influence of the gravitational force. That is, the mechanical energy remains constant throughout the motion of the object. This is known as the *conservation of mechanical energy*.

---

#### ACTIVITY 4-2: THERE AND BACK AGAIN

**Prediction 4-2:** Suppose that the cart is given a push up the ramp and released. It moves up, reverses direction, and comes back down again. How will the kinetic energy change? How will the gravitational potential energy change? How will the mechanical energy change? Describe in words. **Do this before coming to lab.**

Test your predictions:

1. Open the experiment file called **L06.A4-2 Inclined Ramp**. Enter the cart mass as before.
2. Hold the cart at the bottom of the ramp and **START** the experiment. (*Do not put your hand between the cart and the motion detector.*) Give the cart a push up the ramp. Stop the cart when it comes down again close to the bottom. **DO NOT EVER LET THE CART HIT THE MOTION DETECTOR!!** The auto start and stop will again be used to collect the data. The computer starts collecting data when the cart initially passes the 1.6 m point going up and **STOPS** taking data when the cart returns back down through the 1.6 m point.
3. **Print** out one set of graphs for your group report.

**Question 4-2:** How does the mechanical energy change as the cart rolls up and down the ramp? Does this agree with your prediction? Explain.

---

### ACTIVITY 4-3: MECHANICAL ENERGY AND FRICTION

In this experiment we will let the cart only roll down the ramp.

**Prediction 4-3:** Suppose that there is also frictional force acting on the cart in addition to the gravitational force. Then as the cart rolls down the ramp, how will the kinetic energy change? How will the gravitational potential energy change? How will the mechanical energy change? Do not do this before coming to lab.

Test your predictions:

1. Place the friction pad on the bottom of the cart and adjust the knob on the cart so that there is a reasonable amount of friction between the pad and the ramp, but so that the cart still easily rolls down the ramp when released.
2. In this experiment you will again release the cart from the top of the inclined ramp. Open the experiment file called **L06.A4-3 Inclined Ramp**. Using exactly the same setup as Activity 4-2, graph  $KE$ ,  $GPE$ , and mechanical energy as the cart rolls down the ramp. *Data Studio* will again utilize auto start and stop in this experiment. The range is 0.4 – 1.7 m relative to the motion detector at the top. Hold the cart at the top of the ramp about 20 cm from the motion detector and **START** the experiment. Release the cart and catch it at the bottom right before it slams into something. *Data Studio* will automatically stop after car passes 1.7 m. You do not need to click on **STOP**. If your data has bumps, you may need to add the index card to the motion cart.
3. **Print** out one set of graphs for your group report.

**Question 4-3:** Is the mechanical energy constant for the motion of the cart down the ramp *with friction*? In other words, is mechanical energy conserved? If not, explain.

**Question 4-4:** Determine the average frictional force by dividing the energy loss (mechanical energy lost) by the distance the cart moved (Energy =  $F_{\text{friction}} \times \text{distance}$ ). Use an estimate of the distance the cart moved down the ramp.

**Question 4-5:** Determine the coefficient of friction. Show your work.

### INVESTIGATION 5: ELASTIC POTENTIAL ENERGY

As mentioned in the Overview, it is useful to define other kinds of potential energy besides gravitational potential energy. In this investigation you will look at another common type, the *elastic potential energy*, which is associated with the elastic force exerted by a spring that obeys Hooke's law.

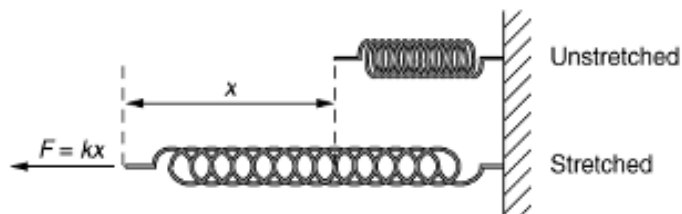

You have seen that the magnitude of the force applied by most springs is proportional to the amount the spring is stretched from beyond its unstretched length. This is usually written  $\mathbf{F} = -k\mathbf{x}$ , where  $k$  is called

the spring constant. The minus sign indicates that this is a *restoring* force.

The spring constant can be measured by applying measured forces to the spring and measuring its extension.

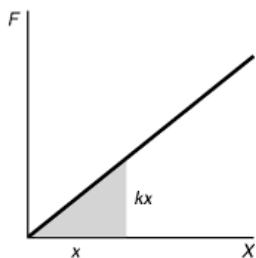

You also saw previously that the work done by a force can be calculated from the area under the force vs. position graph. Shown below is a plot of the magnitude of the force ( $F$ ) vs. position ( $x$ ) for a spring. Note that  $k$  is the *slope* of this graph.

**Question 5-1:** How much work is done in stretching a spring of spring constant  $k$  from its unstretched length by a distance  $x$ ? (**Hint:** Look at the triangle on the force vs. distance graph above and remember how you calculated the work done by a changing force.)

If we define the *elastic potential energy* of a spring to be the work done in stretching the spring, the definition will be analogous to the way we defined *GPE*. In this case, the *elastic potential energy* ( $EPE$ ) would be

$$EPE = kx^2/2 \quad (8)$$

In this investigation, you will measure the kinetic energy, elastic potential energy, and mechanical energy (defined as the sum of kinetic energy and elastic potential energy) of a mass hanging from a spring when air resistance is very small, and again when it is significant. You will see if the mechanical energy is conserved.

**Note:** In the activities that follow you will explore the mechanical energy of a hanging mass oscillating on a spring. The equilibrium position depends on the gravitational force on the mass. However, it can be shown mathematically that the motion of the mass relative to the equilibrium position is only influenced by the spring force and not by the gravitational force. Therefore only  $EPE$  (and not  $GPE$ ) needs to be included in the mechanical energy.

You will need the following:

- force probe
- 50-g mass
- spring
- index card, 4" x 6"
- motion detector
- supports to suspend the force probe and spring
- masking tape

---

**ACTIVITY 5-1: SPRING CONSTANT**

To calculate the elastic potential energy of a stretched spring, you need first to determine the spring constant  $k$ . Since  $F = -kx$ , this can be found by measuring a series of forces  $F$  and the corresponding spring stretches  $x$ .

1. Set up the force probe and motion detector as shown on the left. Use the broad beam of the motion detector. Place the motion detector on the table.

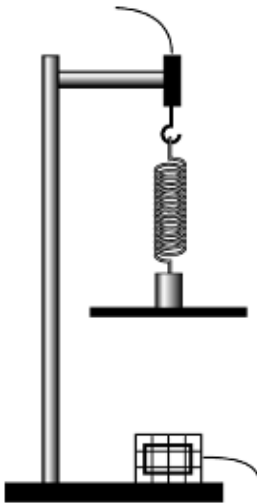

2. Tape a 4" x 6" index card to the bottom of the 50 g mass and hang the mass from the spring. Adjust the index card until it is level. Make sure there is about 70 – 80 cm between the card and the motion detector.
3. Open the experiment file called **L06.A5-1 Spring Constant**.
4. **Start graphing.** Grab the mass from the side (with your arm out of the way of the motion detector) and pull the hanging mass down slowly for about 50 cm. Then stop the experiment before returning the spring to the equilibrium position. The data should fall on a straight line.
5. Use the **fit routine** in the software to find the line that fits your data, and determine the spring constant from the fit equation.

$$k = \underline{\hspace{2cm}}$$

6. Leave the fit equation on your graph and **print** out one set of graphs for your report.

**Question 5-2:** Was the force exerted by the spring proportional to the displacement of the spring from equilibrium (note the position may decrease as force increases because you are pulling towards the motion detector)?

---

**ACTIVITY 5-2: MECHANICAL ENERGY WITH AIR RESISTANCE**

**Prediction 5-1:** Suppose that there is also significant air resistance in addition to the spring force acting on the mass as it oscillates up and down. How will the elastic potential energy change? How will the mechanical energy change? Do not do this before coming to lab.

1. Attach the index card to the bottom of a 50 g mass and measure the total mass.

Mass of 50 g mass and index card \_\_\_\_\_

2. Hang the spring and 50 g mass from the force probe so that the card is about 45 – 60 cm above the motion detector. We find this distance gives best results. Make sure the system is at rest and then **zero** the force probe. The index card must be level when the spring and mass are hanging.
3. Open the experiment file **L06.A5-2 Mechanical Energy Too**. Make sure the Position vs. Time graph is displayed. Let the spring and mass hang at rest. **Start** the experiment and determine the new equilibrium position from the motion detector using the **statistics features** in the software.

Equilibrium position: \_\_\_\_\_

4. We now need to enter several constants into the experiment. Click on the Calculator screen and enter the mass (plus the index card), the Equilibrium position (called Equilibrium Length in Data Studio), and the spring constant you measured in Activity 5-1. Make sure you click on the Accept in the lower screen each time you enter a new number so that Data Studio registers the new value. You may want to check them all again when finished. Then perhaps look at the kinetic energy and elastic potential energy formulas. Click on Accept in upper right screen.
5. We find it works best to lift the mass straight up about 10-15 cm and drop it to begin oscillating, and then **Start** taking data.
6. **Print** out one set of graphs for your group report when you are satisfied. Be sure to look at the Mechanical Energy vs. time graph.

**Question 5-3:** Is the mechanical energy conserved for the motion of the mass *with air resistance*? If not conserved, where did the energy go?

**Question 5-4:** Describe the relationship in your data between the kinetic energy and elastic potential energy.