

Name _____ Date _____ Partners _____

LAB 8: ROTATIONAL DYNAMICS

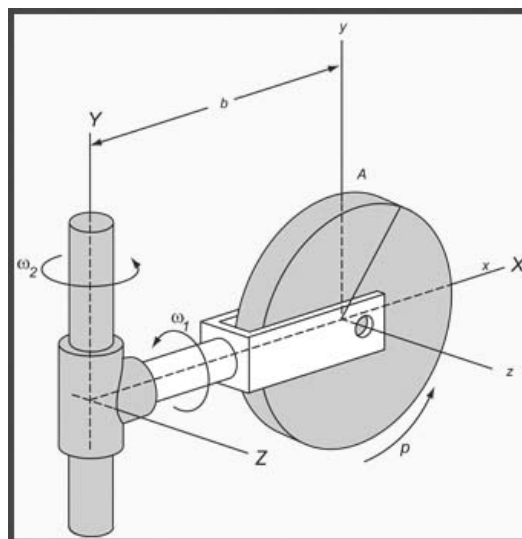

Examples of rotation abound throughout our surroundings

OBJECTIVES

- To study angular motion including angular velocity and angular acceleration.
- To relate rotational inertia to angular motion.
- To determine kinetic energy as the sum of translational and rotational components.
- To determine whether angular momentum is conserved.

OVERVIEW

We want to study the rotation of a rigid body about a fixed axis. In this motion the distance traveled by a point on the body depends on its distance from the axis of rotation. However, the angle of rotation θ , (also called the angular displacement), the angular velocity ω , and the angular acceleration α , are each the same for every point. For this reason, the latter parameters are better suited to describe rotational motion. The unit of angular displacement that is commonly used is the radian. By definition, θ is given in radians by the relation $\theta = s/r$, where s is the arc length and r is the radius as shown in Fig 1.

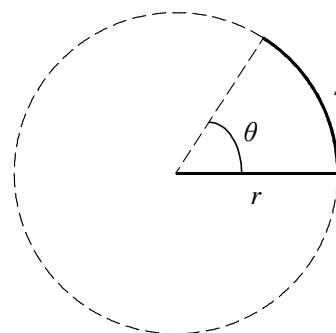

Fig 1. Definition of s , r , and θ .

One radian is defined as the angle (see θ in Fig. 1) that subtends an arc (labeled as s in Fig. 1) equal in length to the radius (r in Fig. 1). An angle of 90° thus equals $\pi/2$ radians, a full turn 2π radians, etc. The angular velocity is the rate of change of the angular displacement with time. It is equal to the angle through which the body rotates per unit time and is measured in radians per second. The angular acceleration is the rate of change of the angular velocity with time and is measured in radians per second squared.

$$\omega = \lim_{\Delta t \rightarrow 0} \frac{\Delta \theta}{\Delta t}$$

$$\alpha = \lim_{\Delta t \rightarrow 0} \frac{\Delta \omega}{\Delta t}$$
(1)

In linear motion the position, velocity, and acceleration are described by vectors. Rotational quantities can also be described by (axial) vectors. In these experiments, however, you will only have to make use of the magnitudes and signs of these quantities. There will be no explicit reference to their vector character.

Sometimes one needs the parameters of the linear motion of some point on the rotating rigid body. They are related very simply to the corresponding angular quantities. Let s be the distance a point moves on a circle of radius r around the axis; let v be the linear velocity of that point and a its linear acceleration.

Then s , v , and a are related to θ , ω , and α by

$$s = r\theta \qquad v = r\omega \qquad a = r\alpha$$
(2)

Let us now imagine a rigid body of mass m rotating with angular speed ω about an axis that is fixed in a particular inertial frame. Each particle of mass m_i in such a rotating body has a certain amount of kinetic energy $\frac{1}{2}m_i v_i^2 = \frac{1}{2}m_i r_i^2 \omega^2$. The total kinetic energy of the body is the sum of the kinetic energies of its particles.

If the body is rigid, as we assume in this section, ω is the same for all particles. However, the radius r may be different for different particles. Hence, the total kinetic energy KE of the rotating body can be written as

$$KE = \frac{1}{2}(m_1 r_1^2 + m_2 r_2^2 + \dots) \omega^2 = \frac{1}{2} \left(\sum m_i r_i^2 \right) \omega^2.$$
(3)

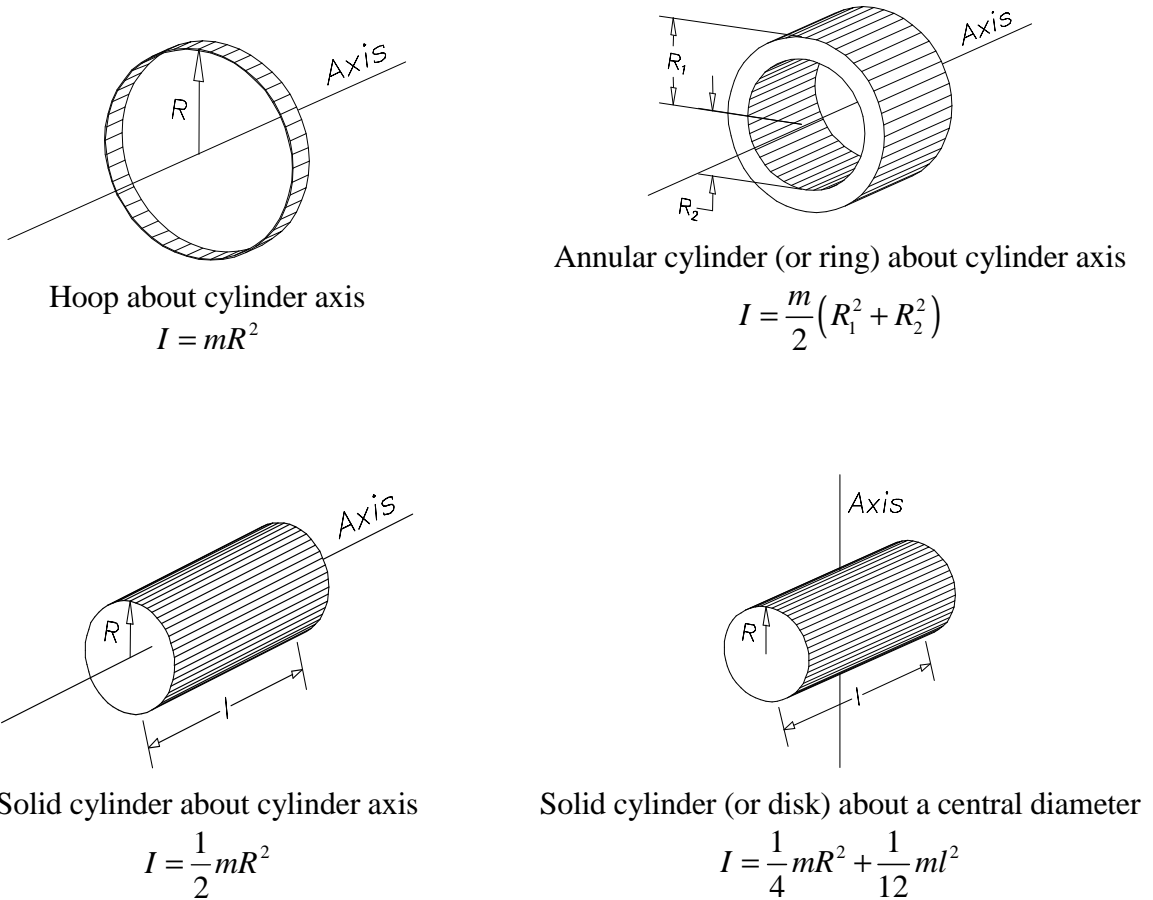

Figure 2. Rotational Inertia for some simple geometries.

The term $\sum m_i r_i^2$ is the sum over i of the products of the masses of the particles by the squares of their respective distances from the axis of rotation. We denote this quantity by the symbol I . I is called the **rotational inertia, or moment of inertia, of the body with respect to the particular axis of rotation.**

The rotational inertia I has dimensions of $[ML^2]$ and is usually expressed in $\text{kg}\cdot\text{m}^2$. For example, some simple shapes are given in Fig. 2. Note that the rotational inertia of a body depends on the *particular axis about which it is rotating* as well as on the *shape of the body* and the *manner in which its mass is distributed*.

In terms of rotational inertia, we can now write the kinetic energy of the rotating rigid body as:

$$KE_{rot} = \frac{1}{2}I\omega^2. \tag{4}$$

This is analogous to the expression for the kinetic energy of translation of a body, $KE_{tran} = \frac{1}{2}mv^2$. We have already seen that the angular speed ω is analogous to the linear speed v . Now we see that the rotational inertia I is analogous to the translational inertial mass m .

The rotational analog to force is *torque* (denoted by τ). τ is related to F by $\tau = rF$ (for r perpendicular to F)

In rotational dynamics, Newton's second law ($F = ma$ where F is the force, m is the mass and a is the acceleration) becomes:

$$\tau = I\alpha \quad (5)$$

Recall that in the absence of external forces, linear momentum is conserved. Similarly, in the absence of external torques, angular momentum is conserved. Finally, if no non-conservative forces (such as friction) or torques act, then mechanical energy is conserved. In summary, you will test the following conservation principles in this experiment:

1. $E_{potential} + E_{linear\ kinetic} + E_{rotational\ kinetic} = \text{constant}$
2. The sum of the angular momentum = constant

In Table 1, we compare the translational motion of a rigid body along a straight line with the rotational motion of a rigid body about a fixed axis.

Table 1. Rectilinear and Rotational Quantities

Rectilinear Motion		Rotation About a Fixed Axis	
Displacement	x	Angular displacement	θ
Velocity	$v = \frac{dx}{dt}$	Angular velocity	$\omega = \frac{d\theta}{dt}$
Acceleration	$a = \frac{dv}{dt}$	Angular acceleration	$\alpha = \frac{d\omega}{dt}$
Mass (translational inertia)	$m = \int \rho dV$	Rotational inertia	$I = \int r^2 \rho dV$
Linear momentum	$p = mv$	Angular momentum	$L = I\omega$
Kinetic energy	$KE = \frac{1}{2}mv^2$	Kinetic energy	$KE = \frac{1}{2}I\omega^2$
Force	$F = ma$	Torque	$\tau = I\alpha$
Work	$W = \int F dx$	Work	$W = \int \tau d\theta$
Power	$P = Fv$	Power	$P = \tau\omega$

INVESTIGATION 1: EXPERIMENTAL SETUP

You will need to have the following apparatus for these experiments:

- rotational dynamics kit
- 20 g mass
- thread
- meter stick
- vernier calipers
- air supply
- digital extension cable
- electronic balance

WARNING: DO NOT MOVE THE ROTATING DISKS UNLESS THE AIR SUPPLY IS ON. THE TA MUST ASSIST WHENEVER DISKS ARE CHANGED.

ACTIVITY 1-1: APPARATUS LEVELING

1. The clearance between the spindle and disks is only about 0.001" (0.0254 mm), and any nicks will damage the low friction support. The Rotational Dynamics apparatus is connected to an air supply with a pressure regulator. The pressure should be preset at about 10 psi (with air flowing) for operation.
2. Arrange the apparatus (see Fig. 3 below) so the air-bearing pulley extends over the edge of your lab table. Check with your TA if you are unsure.
3. To ensure that the disk rotates with uniform velocity or acceleration, even with an eccentric load, the apparatus must be leveled accurately.
4. Turn on the air with the top aluminum disk on the spindle. If the disk on the apparatus is not made of aluminum, ask your TA to put it on.
5. Place bubble level on top of the aluminum disk and verify that the apparatus is level. If it is not, adjust the three leveling feet until it is.

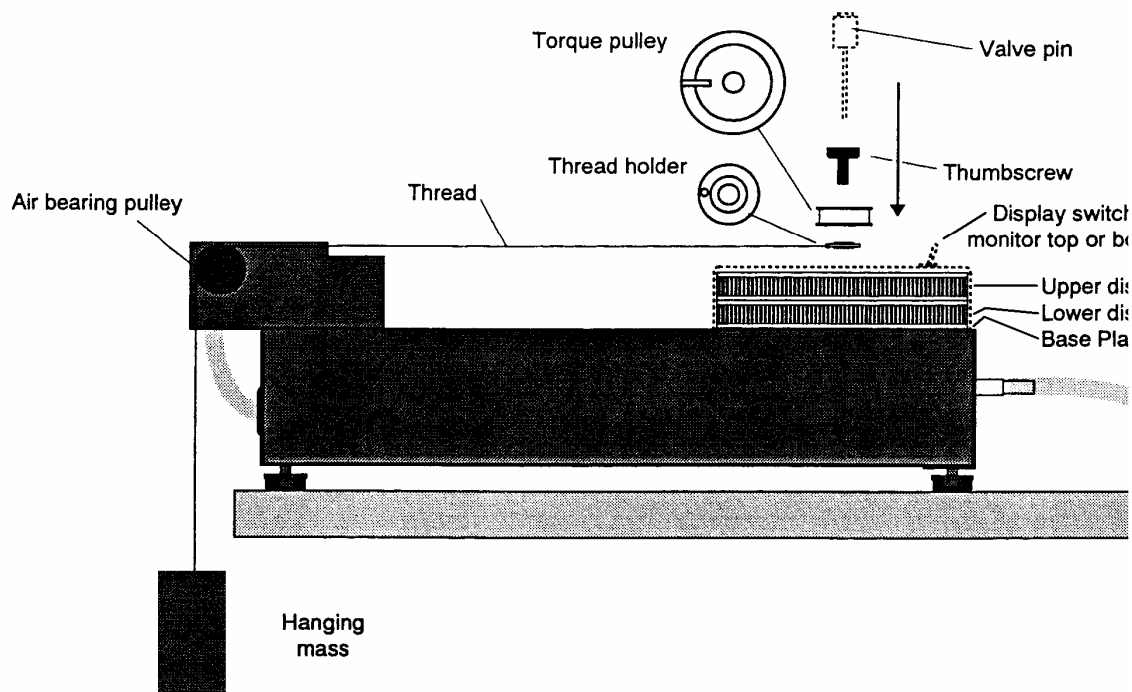

Fig. 3. Side view of rotational dynamics apparatus

ACTIVITY 1-2: DISK ROTATION

1. The two disks can spin independently or together, or the upper disk can spin while the lower disk does not (see Fig. 3). These options are controlled using the two valve pins that are provided with the unit. When not in use, these pins can be stored in the valve pin storage holes on the top of the base (see Fig. 4). Start with the pins in the storage holes.
2. Place one valve pin in the bottom disk valve, located next to the valve pin storage holes. Give the upper disk a spin. Notice that it lies firmly on the lower disk so the two disks spin together. However, the aluminum disk is so light that it may hover briefly before catching the bottom disk. Remove the valve pin and notice how both disks drop onto the base plate.
3. Replace the valve pin in the bottom disk valve and then place the remaining valve pin into the hole in the middle of the upper disk, as in the figure. Now spin the disks in opposite directions. Notice that the two disks now spin independently.

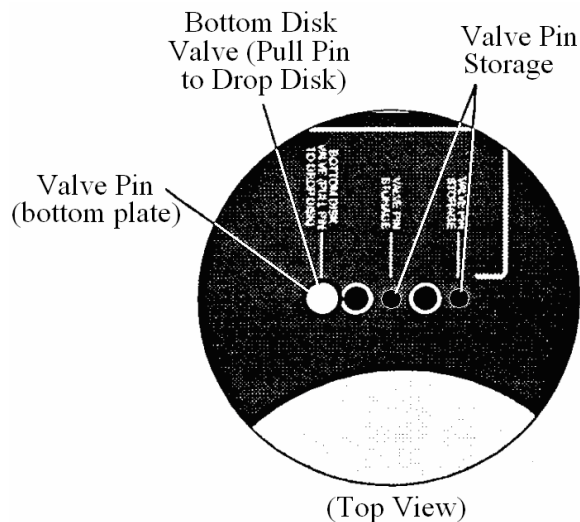

Fig. 4. View of the pin storage area.

4. Pull the valve pin from the center of the upper disk. The upper disk drops onto the lower disk so that the disks now spin together, as a single rotating body. This is the rotational equivalent of an inelastic collision. You may find that the aluminum disk tends to float a bit, because it is so much lighter than the steel disk.

The theoretical rotational inertia of the rotating disks (annular cylinders) is given by (see Fig. 2)

$$I = \frac{1}{2} M (R_1^2 + R_2^2), \quad (6)$$

where M is the mass of the disk, and R_1 and R_2 are the disk's outer and inner radii, respectively. The masses are

Bottom stainless steel:	1,344 grams
Top stainless steel:	1,357 grams
Top aluminum:	464 grams

The geometric shape of the disks are not identical; however, within the accuracy of your measurement you can use for all three disks:

$$R_1 = 63.2 \text{ mm and } R_2 = 7.9 \text{ mm.}$$

5. Calculate (if you have not already done so) the rotational inertia of disks.

rotational inertia I _____ $\text{kg}\cdot\text{m}^2$ (bottom stainless steel)

rotational inertia I _____ $\text{kg}\cdot\text{m}^2$ (top stainless steel)

rotational inertia I _____ $\text{kg}\cdot\text{m}^2$ (aluminum)

INVESTIGATION 2: ROTATIONAL KINEMATICS AND TORQUE

ACTIVITY 2-1 HOW DOES TORQUE AFFECT AN OBJECT'S ROTATIONAL MOTION?

We want to verify the rotational analogue of the relationship between force and acceleration as given by Equation (5). We will apply a constant torque to an aluminum disk by attaching a mass to a string wrapped around the disk and then hanging the mass over a frictionless pulley. The constant force due to gravity acting on the mass ($F_{\text{gravity}} = mg$) is transferred to the disk by the string hanging over the pulley as a constant tension.

Prediction 2-1: Explain what will happen to the disk when the mass hanging down over the pulley is released. Does this represent a constant torque?

Question 2-1: If you have the means to measure the angular velocity of the disk as a function of time, how can you determine if the angular acceleration is constant?

The tension in the string causes a torque on the disk since the string is attached to the disk via a small pulley (with a nominal radius of 12.5 mm). When the disk is released, it will start to rotate with constant angular acceleration as the mass falls with constant linear acceleration. We will measure this angular acceleration by plotting the angular velocity of the disk over time. Because $\omega = \alpha t$, if we fit a straight line to the angular velocity data, the slope of the line will give us the angular acceleration of the disk. We will then see if this angular acceleration agrees with the angular acceleration calculated by solving the force equations for the disk and the mass.

1. Remove the valve pin for the bottom disk so that the bottom disk does not rotate. **Make the measurements using the lighter aluminum top disk.** If the disk on the apparatus is not made of aluminum, ask your TA to put it on. **Do not replace the disks yourself!**
2. Cut a piece of thread about 135 cm in length.
3. Measure the diameter of the small pulley and record the radius below.

r : _____ mm

4. Referring to Fig. 3, tie one end of the thread to the hole in the thread holder. Place the thread holder in the recess of the small torque pulley, with the thread passing through the slot in the pulley. Then use the thumbscrew to attach the pulley to the top of the rotating disk, with the flat side of the pulley facing up, so the thread holder is underneath the pulley. Tighten the thumbscrew so the pulley is secure. *Make sure that the string is not caught under the pulley!* Weigh the “20 g” mass.

m : _____ g

5. Attach the 20 g mass to the other end of the thread. When the thread is fully extended, the mass should almost touch the floor.
6. Open the experimental file **L08.A2-1 Angular Velocity**. This will set up the computer to graph the angular velocity of the disk in deg/sec.
7. Rotate the disk until the mass is approximately 90 cm above the floor. It may help to tape a meter stick directly to the edge of the table near the nylon string. Start the computer and immediately release the disk. Stop the computer and catch the mass when the mass has fallen at least 80 cm.
8. As the mass falls, the disk will rotate with constant angular acceleration and the angular velocity on the graph should increase linearly. Using the mouse, select a

region in the middle of the data where you are sure the mass was falling freely. Click on the **Fit** icon on the graph toolbar and select Linear Fit. Record the slope of the fit (m) here:

Slope _____ deg/sec².

9. **Print** a copy of the graph with **Fit** displayed.
10. Because the disk is rotating on a nearly frictionless layer of air, the only torque acting on it is from the tension in the string. We can write the force and torque equations for the mass and the disk as:

$$\text{Forces on mass: } F_{\text{net}} = mg - T = ma$$

$$\text{Torques on disk: } \tau = I\alpha$$

where T is the tension in the string, m is the mass, and a is the linear acceleration of the mass. Solving the force equation for T gives $T = mg - ma$. Because the mass is attached to the edge of the torque pulley, the magnitude of the linear acceleration of the mass is the same as the magnitude of the linear acceleration of the outer edge of the torque pulley. Using Equations (2) and (5) we can rewrite the torque equation above as:

$$\tau_{\text{net}} = Tr = (mg - m\alpha r)r = I\alpha \quad (7)$$

where τ is the torque on the disk, T is the tension in the string, r is the radius of the torque pulley, and α is the angular acceleration of the disk. Solving the above equation for α gives:

$$\alpha = \frac{mgr}{(I + mr^2)} \quad (8)$$

You calculated the rotational inertia previously, so calculate α using the expression above and compare with the value of the angular acceleration of the disk you obtained from your data.

$$\alpha = \text{_____ rad/s}^2 \text{ (calculated)}$$

$$\alpha = \text{_____ rad/s}^2 \text{ (experimental)}$$

$$\text{Difference in } \alpha \text{ _____ \%}$$

Question 2-2: How did your results compare? If instead of angular velocity data you were given angular position data, what type of fit would you need to perform to find the angular acceleration of the disk?

INVESTIGATION 3: CONSERVATION OF ENERGY

ACTIVITY 3-1 DOES POTENTIAL ENERGY LOST EQUAL KINETIC ENERGY GAINED?

We want to demonstrate that mechanical energy is conserved in the absence of non-conservative forces (such as air resistance or friction). We will apply a torque to a pulley attached to the aluminum disk via a thread attached to a small hanging mass. We will examine if the potential energy lost by the mass as it falls is equal to the gain in the linear kinetic energy of the mass and the rotational kinetic energy of the disk. The weight of the mass supplies a constant torque that accelerates the rotating disk.

Because mechanical energy is conserved as the mass falls, the initial potential energy of the hanging mass m is converted to kinetic energy. After falling a distance s^* , the mass loses an amount of potential energy, mgs . The mass has a translational kinetic energy due to its velocity v and rotational kinetic energy due to the upper disk rotating with an angular velocity ω . For energy to be conserved, the following relation must hold:

$$mgs = \frac{1}{2}mv^2 + \frac{1}{2}I\omega^2 \quad (9)$$

Now, $v = \omega r$, where r is the distance from the axis where the torque is applied, i.e. the radius of the *torque pulley*. Using the equations relating angular quantities to linear quantities, we can rewrite Eq. (9) as

$$\begin{aligned} mgs &= \frac{1}{2}mv^2 + \frac{Iv^2}{2r^2} \\ mgs &= \frac{1}{2}mv^2 \left(1 + \frac{I}{mr^2}\right) \end{aligned} \quad (10)$$

where I is found using Eq. (6).

* This distance is the same as the distance that a point on the outer edge of the pulley traces out, $s = r\theta$.

(Note that by differentiating both sides of Eq. (10) with respect to time we can see that the linear acceleration of the mass ($a = \frac{dv}{dt} = \frac{d^2s}{dt^2}$) is constant in this situation.)

Therefore, the angular acceleration of the disk ($\alpha = a/r$) and the torque applied to the disk ($\tau = I\alpha$) are also constant. Hence, when the disk is released, the mass descends, moving with constant linear acceleration and causing the disks and axle to rotate with constant angular acceleration.

We will now perform an experiment to verify that mechanical energy is conserved by calculating and comparing the left hand and right hand sides of Eq. (10).

1. Open the experimental file **L08.A3-1 Conservation of Energy**. The Calculator window should be open. Enter your values for m , the mass of the hanging weight, r , the radius of the torque pulley, and I , the rotational inertia of the upper disk. Make sure you insert the values with the units shown in the window. You must click on “Accept” in the lower part of the window every time you enter new units. After you are finished entering the correct values, go back and check that they were accepted. Close the Calculator window.
2. An energy graph will remain visible. The linear kinetic and gravitational potential energies of the hanging mass and the rotational kinetic energy of the disk will be graphed, as will their sum, the total mechanical energy. Note that we have chosen the “zero” for potential energy to be when the mass is at its highest point. The total mechanical energy will therefore initially be zero as well.
3. Turn on the air and rotate the disk until the mass is approximately 90 cm above the floor. **Start the computer**, release the disk, and let the mass drop. **Stop the computer** just before the string runs out on the pulley and the mass “rebounds”.
4. **Print** out a copy of the graph for your report.

Question 3-1: How well do your results support the contention that mechanical energy is conserved? Discuss your actual values for kinetic, potential, and total mechanical energy.

Question 3-2: Can you easily identify the linear kinetic energy of the mass? What is its value when the mass is at its lowest point? How can you more easily see it? What is the ratio of the mass kinetic energy to the disk rotational kinetic energy. Why is this value such an extreme?

Mass linear KE: _____ Disk rotational KE: _____

Ratio: mass linear KE/disk rotational KE: _____

Prediction 3-1: Discuss what would happen if you applied a frictional torque to the disk. How would the energy graphs be different?

5. Repeat step 3, but this time use your finger to apply a little friction to the spinning disk (but not so much as to keep it from spinning).
6. **Print** out a copy of the graph for your report.

Question 3-3: How well do your results agree with your prediction when friction acts on the system? Explain the results you obtained.

INVESTIGATION 4: CONSERVATION OF ANGULAR MOMENTUM

ACTIVITY 4-1: IS ANGULAR MOMENTUM CONSERVED?

Angular momentum, $L = I\omega$, is conserved whenever there are no *external* torques. In the case of rotating disks that engage each other, all torques are *internal* and we expect to have conservation of angular momentum.

In this measurement, you will use the optical reader on the Rotational Dynamics apparatus, which counts the black bars on the disks as they pass. Each LED comes on when the corresponding optical reader senses a black bar and goes off when it detects a white bar. Using this data, the computer will display a graph of angular velocity vs. time.

1. Remove the torque pulley and mass. Ask your TA to remove the top aluminum disk and replace it with the top stainless steel disk. Replace valve stems so both bottom and top disks rotate separately.
2. Open experiment file **L08.A4-1 Angular Momentum**. You will see a graph showing the angular velocity of each disk vs. time. Ch 1 should show data from the upper disk and Ch 2 should show data from the lower disk. Verify this by starting the computer and spin one of the disks while holding the other one still. What happens when you reverse the direction of the spin?
3. Perform the following four experiments. Then calculate the initial and final angular momentum and determine whether it is conserved. Enter your data and calculations in Table 4-1. For purposes of this calculation assume that both stainless steel disks have the same rotational inertia. Remember that the angular velocity ω can be negative. You need to keep track of its sign. Data Studio always indicates a positive number.

Note: Completing Table 4-1 is time consuming. It is crucial for at least one team member to be working on these calculations throughout the experiments.

Table 4-1. Conservation of Angular Momentum

	Part a	Part b	Part c	Part d
ω Initial Top				
ω Initial Bottom				
ω Final				
L Initial Total				
L Final				
L Difference				

- a. **Top disk spinning; bottom disk stationary:** Start the computer, hold the bottom disk stationary, and give the top disk a spin, so that its angular velocity is between 600 and 800 deg/sec. Wait for a couple of seconds, release the bottom disk and pull the valve pin from the top disk so that the top disk falls onto the bottom disk. Wait for *two full* seconds and then stop the computer. Record the angular velocity of each disk just before and after releasing the valve. You will get a better reading by finding a range of data points for each measurement and using the statistics function to find the mean of these values. Enter your data in Table 4-1.

Question 4-1: How well do the initial and final angular momentum agree? Is this good enough agreement? Explain.

- b. **Top and bottom disks spinning in the same direction but at different rates:** Perform the same procedure as in part a, but this time spin both disks in the same direction but at different rates, at least 200 deg/s apart. Enter your data into Table 4-1.

Question 4-2: How well do the initial and final angular momentum agree? Is this good enough agreement? Explain.

- c. **Top and bottom disks spinning in opposite directions at different rates:** Spin both disks in opposite directions and at different rates. Make sure to record the direction in which each disk is spinning, i.e. clockwise or counter-clockwise. Since the sensors have no way of knowing which direction the disks are spinning, the angular velocity of each disk will be positive on the graph even though they are spinning in opposite directions. Remember that this will make one disk's angular momentum negative relative to the other's. Perform the same procedure as in part a and enter your data into Table 4-1.

Question 4-3: How well do the initial and final angular momentum agree? Is this good enough agreement? Explain.

- d. **Top and bottom disks spinning in opposite directions at the same rate:** Try to spin the two disks at the same rate but in opposite directions. Follow the same procedure as in part a and enter your data into Table 4-1.

Question 4-4: What happened when you removed the pin? How well do the initial and final angular momentum agree? Is this good enough agreement? Explain.

Question 4-5: Discuss possible sources of error in this activity.

**Turn off the Rotational Dynamics apparatus and the AIRFLOW.
The TA should check this at the end of the lab period.**