

Name _____ Date _____ Partners _____

LAB 9: EQUILIBRIUM OF NON-PARALLEL FORCES

OBJECTIVES

- To study the components of forces
- To examine forces in static equilibrium
- To examine torques
- To study the conditions for rotational equilibrium

OVERVIEW

A particle is in static **equilibrium**, i.e. will not be accelerated, if the net force acting on it is zero. Another way of expressing this condition is to say that the vector sum of all the forces \mathbf{F}_i is zero.¹

$$\sum_{i=1}^n \mathbf{F}_i = \mathbf{0} \quad (1)$$

The same holds true for an extended body provided the lines along which the various forces act all intersect at a common point.

If the lines of force do not intersect at a common point, the body will be set into rotation even though the vector sum of the forces may equal zero. If we want the term equilibrium to include the absence of a rotational acceleration we must supplement Eq. (1) with the condition that all the **torques** acting on the body add up to zero as well.

What is a torque?

Imagine that a force \mathbf{F} is applied to various points on a body that is free to rotate around a pivot point P , as shown in Figure 1. If the line along which this force acts passes through P , no rotation will result. If the force acts at point A_1 that lies on a line that passes at finite distance r_1 from P , the body will begin to rotate around P .

Experience shows that the body will tend to rotate more readily if the same force \mathbf{F} is given more leverage,

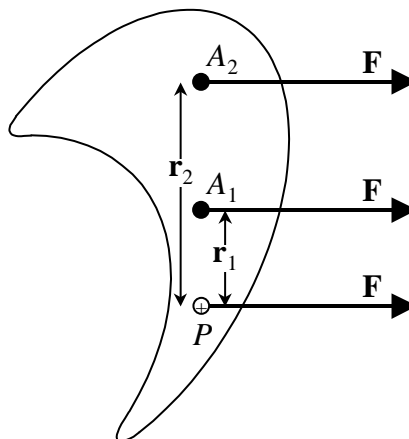

Figure 1. Three forces \mathbf{F} acting at three points.

¹ For a review of vectors, refer to Appendix E: Vectors.

e.g. by applying it at A_2 , at a distance $r_2 > r_1$, from P . In this example the force acts at points P , A_1 , and A_2 , that all lie on a line that is perpendicular to the force. In the general case, shown in Figure 2., this need not be so. Here the force \mathbf{F} acts at a point A that is at a distance r from the pivot point P . Now imagine that this force were transmitted by a string and that a thumbtack were pushed through that string at the point B . Clearly the **initial** situation would remain quite unchanged²; in other words, the only thing that counts is the perpendicular distance r_\perp from the line of action (force) to the pivot point. This distance is called the **moment arm** of the force around P . The product of the force F and its moment arm r_\perp is called the **torque** and is denoted by the Greek letter τ (pronounced tau):

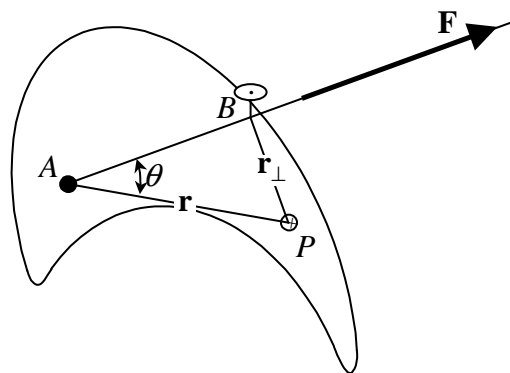

Figure 2. A force \mathbf{F} acts at a point A away from the pivot point P .

$$\tau = r_\perp F. \quad (2)$$

In the SI system a torque is measured in Newton-meters. A look at Figure 2. shows that

$$r_\perp = r \sin \theta. \quad (3)$$

so that a useful expression of the torque due to a force acting on an arbitrary point becomes

$$\tau = rF \sin \theta. \quad (4)$$

Using vector notation, we have

$$\boldsymbol{\tau} = \mathbf{r} \times \mathbf{F}. \quad (5)$$

The greater the torque applied to an object, the greater will be the angular acceleration of that object, i.e. the faster it will spin up. The condition for a body to be in **rotational equilibrium** is that the (vector) sum of the torques acting upon it about any point is zero:

$$\sum_i \boldsymbol{\tau}_i = \mathbf{0}. \quad (6)$$

If the sum of the torques on a body is zero about any one point, it is zero about *all* points. Hence the location of the point about which torques are calculated in an equilibrium problem is arbitrary. In this experiment you will study the conditions required for a body to be in equilibrium under the action of several forces that are not parallel although they will all lie in one plane, i.e. the torques will be parallel.

² As the body starts to rotate, the angle θ will, of course, change differently in the two situations.

APPARATUS

- drawing board
- four clamp pulleys
- string
- protractor
- three steel balls
- set of hooked masses
- thumbtacks
- large washer

INVESTIGATION 1: FORCES IN STATIC EQUILIBRIUM

We have seen that, in order for an extended rigid body to be in equilibrium, the forces acting on it must satisfy two conditions. The sum of the forces must be zero, and the sum of the torques produced by the forces must be zero. For parallel forces the rules for the addition of forces are simple: forces are either positive or negative and one merely takes their algebraic sum.

When the forces are not parallel, the rules for addition become more complicated. Forces are no longer merely positive or negative. To deal with this situation, a branch of mathematics, called vector algebra, has been developed (see *Appendix E*).

Similarly, torques are complicated to add when the forces are not coplanar. In this experiment, however, we will restrict ourselves to coplanar forces and so the torques will only be clockwise or counterclockwise (negative or positive).

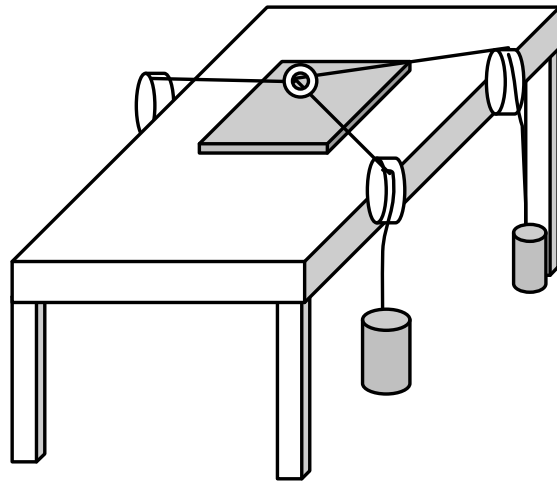

Figure 3. Arrangement of drawing board, washer, string and pulleys

1. Because torques complicate matters, we first study a situation without them: Attach three strings to the washer and let them run over the three pulleys, mounted two on one side of the table, and one on the other as shown in Fig. 3. Hook masses, each greater than 200 g, to the ends of these strings so that the washer remains in equilibrium somewhere near the center of the drawing board; this will require some experimentation. Make sure that

- the pulleys are oriented so that the strings run through the middle of the grooves, and
- the tops of the pulleys are at approximately the same height as the washer.

A large piece of paper tacked to the drawing board under the washer provides a convenient means to draw a diagram of the forces. Clearly the forces are in line with the strings, and can be represented by arrows pointing along the string from the ‘point’ (the center of the washer). Represent the **magnitude** of the force ($F_i = m_i g$)

by the **length** of the arrow. Choose a convenient scale like one centimeter per 10 grams of mass on the string. The resulting diagram should look similar to 4.

- Since the washer is in equilibrium, we know the vector sum of the three forces is zero. Choose one of the force vectors to be a reference (\mathbf{F}_3 in Fig. 4) and measure the angles that the other force vectors make with the reference. Using the magnitudes and angles, calculate the parallel and orthogonal components of the force vectors relative to the reference.

Question 1-1: Do the components algebraically add to zero?

- Of course, you may not get exactly zero because of experimental errors. Estimate how big these errors might be by experimenting: Move the washer 10-20 cm from its equilibrium position, release it, and mark where it comes to a stop; repeat this several times so that you have a scatter of points on your paper.

Question 1-2: How widely are the points dispersed?

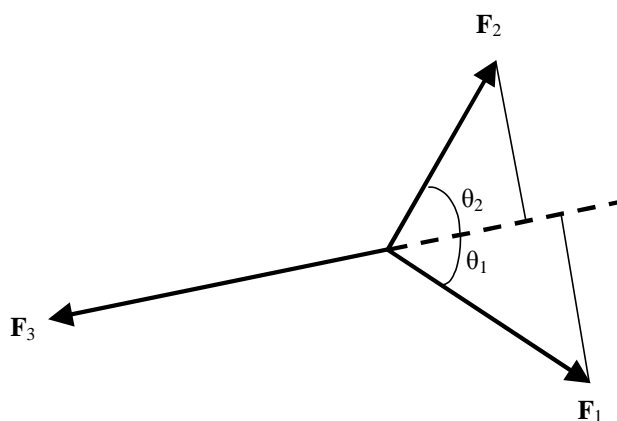

Figure 4. The vector sum of the three forces is zero in equilibrium.

If the dispersion is greater than 5 cm, ask the TA to replace the pulley that seems not to turn freely and repeat the experiment.

Question 1-3: How reproducible are the values for the resulting forces?

- Now, add about 50 g to one of the masses and obtain another scatter of points.

Question 1-4: What can you say about the precision of this experiment? Is the theory verified within experimental limits?

INVESTIGATION 2: ROTATIONAL EQUILIBRIUM

1. Once you have understood how three forces act together at a point, you can go on to study **torques**. Tack another piece of paper to the drawing board. Attach three strings to tacks at three points near the edges of the paper (but not so close as to make it impossible to draw the force vectors). Set the board on the three steel balls so that it is free to move around, and again set up three forces that hold the board in equilibrium. The equilibrium will be found more easily if you use rather strong forces (i.e., large masses). Use the same method as above to draw a diagram of the three forces on the paper, starting the three arrows from the points at which the forces are applied. Fig. 5 shows a possible example.

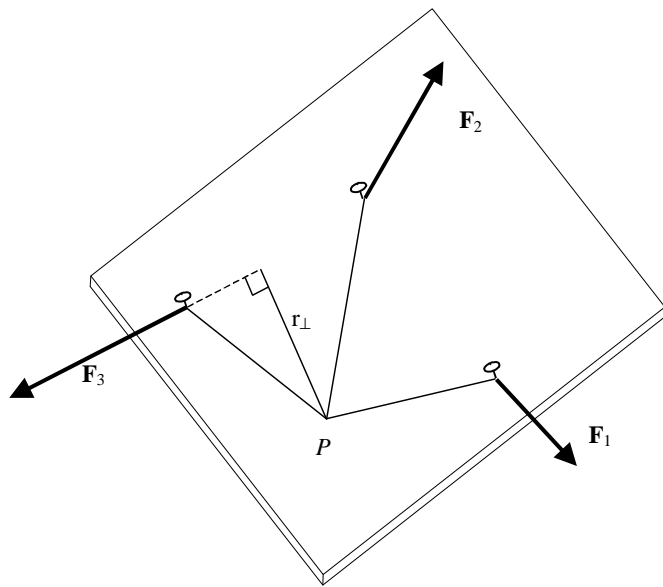

Figure 5. The board is placed on 3 steel balls so torques can be studied.

Question 2-1: Verify first that the vector sum of the three forces is again zero (within the experimental error) when they are added as before. To do this, calculate the components and add them up without regard to where the forces are applied.

- Having found the forces, you are ready to consider the torques acting on the board. Each of the three forces is trying to turn the board as well as to move it laterally. Yet there is neither linear motion nor rotation so both the forces and the torques must add up to zero. To check this, choose an arbitrary point P on your paper, and find the moment arms r_{\perp} (i.e. the perpendicular distance of the force's line of action from the point as shown in Fig. 6a) of the three forces. Note that your choice of point P may make your calculation easier. Use one such point.

Question 2-2: Compute the torques using Eq. (2) and verify that they add up to zero, within the experimental uncertainty.

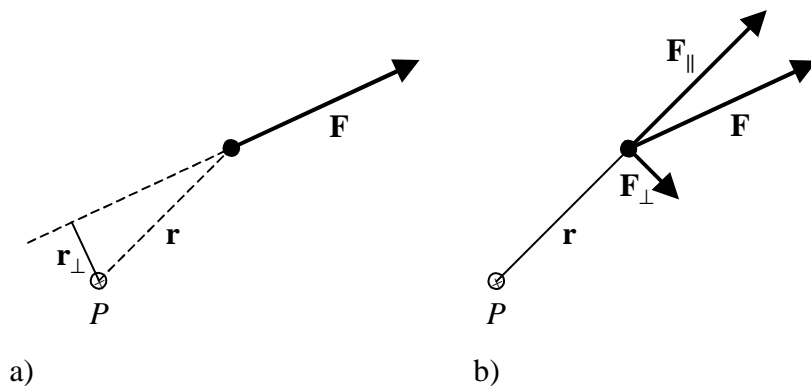

Figure 6. A vector force \mathbf{F} can be broken down into parallel and perpendicular component vectors with respect to any direction.

- It is interesting to notice that the same problem could have been approached in a different way. First of all notice that, mathematically:

$$\tau = Fr_{\perp} = F(r \sin \theta) = r(F \sin \theta) = rF_{\perp}, \quad (7)$$

where F_{\perp} is the component of the force perpendicular to the line joining the pivot P to the force's point of application (see Fig. 6b). The torque of a force with respect to a given point is then also given by the perpendicular component F_{\perp} of the force times its distance r from the point. Such a result can be given the following interpretation: With reference to Figure 6.b, notice that the parallel component F_{\parallel} can only produce a translation of the point P , and no rotation around it, so that the whole effect of rotation can be attributed to the torque of the component F_{\perp} . The torque, then, is given by the product of F_{\perp} by *its* moment arm. It is easy to verify that the moment arm of F_{\perp} is in fact given by the distance r , i.e. $\tau = F_{\perp}r$.

Question 2-3: Verify all this by computing the sum of the torques by this second method: From your graph, derive the components F_{\perp} of the three forces and compute the sum of the products $F_{\perp}r$ (always keep in mind the sign convention) and verify again the zero value of the sum.

PLEASE CLEAN UP YOUR LAB AREA!

